

ANGp101/RES/LT/UHV - goniometer for "phi" tilting

1002803

Technical Specifications

Size and Dimensions	
footprint; height	24 mm x 24 mm; 11 mm
distance center of rotation to top	51 mm
weight	18 g
height	11 mm
Materials	
positioner body	titanium
actuator	PZT ceramics
connecting wires	insulated twisted pair, copper
Coarse Positioning Mode	
travel range (step mode)	5.4 °
maximum drive velocity @ 300 K	~ 1 °/s
input voltage range	0 - 60 V
Fine Positioning Mode	
fine positioning resolution	no fine positioning capability
Position Encoder	
readout mechanism	resistive sensor
encoded travel range	full travel
sensor resolution	0.1 m°
sensor power (when measuring)	0.01 - 1 mW
repeatability	2 m°
Load (@ ambient conditions)	
maximum load	100 g
maximum dynamic force along the axis	2 N
General Specifications	
environment	/LT/UHV

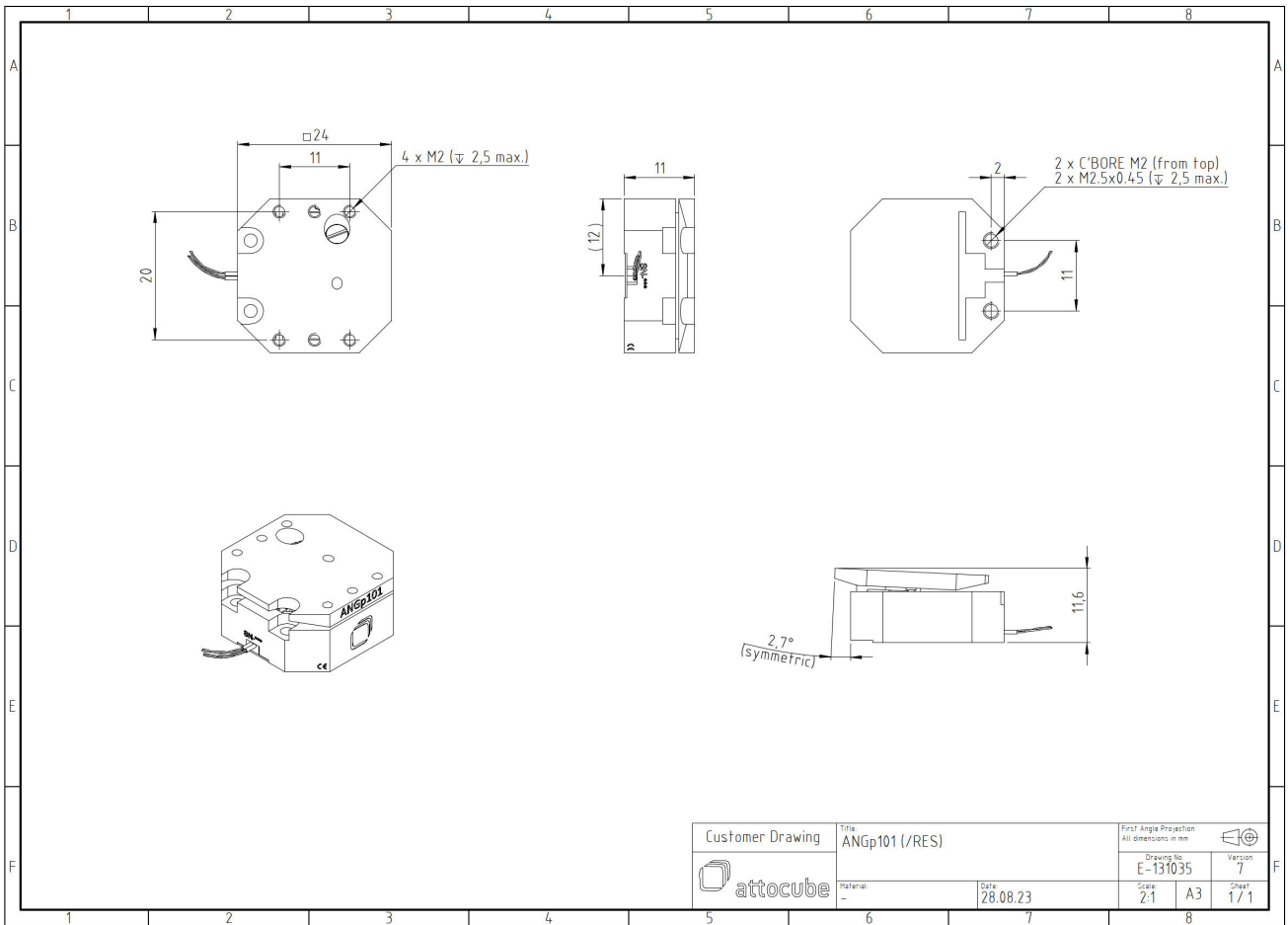

Customer Drawing	Title: ANGp101 (/RES)		First Angle Projection All dimensions in mm	
	Material: -		Drawing No: E-131035	Version: 7
Date: 28.08.23		Scale: 2:1	A3	Sheet: 1 / 1